

# Grinding Test

Grinding Test before mass production.  
We can provide the grinding conditions.

## Compatible Models:

### Vertical Sindle Grinder VGF300



Typical Grinding Applications

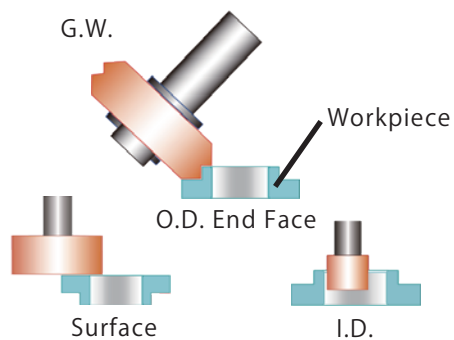

| Item                |              | Specification              |
|---------------------|--------------|----------------------------|
| Grinding Area       |              | Surface/O.D. End Face/I.D. |
| Grinding Range (mm) | O.D.(Max.)   | $\phi$ 350                 |
|                     | Height(Max.) | 180                        |

### Internal Grinder KIH80II



Typical Grinding Applications

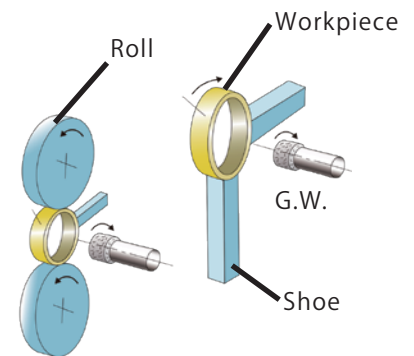

| Item                |                   | Specification         |
|---------------------|-------------------|-----------------------|
| Grinding Area       |                   | I.D.                  |
| Grinding Range (mm) | I.D.(Min. ~ Max.) | $\phi$ 10 ~ $\phi$ 80 |
|                     | Height(Max.)      | 50                    |

### Centerless Grinder C3510



Typical Grinding Applications

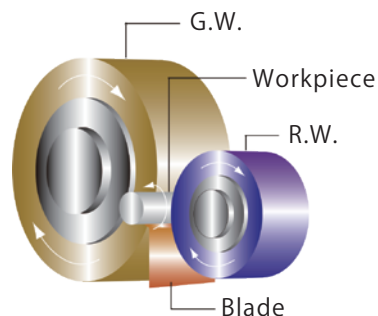

| Item                |              | Specification          |
|---------------------|--------------|------------------------|
| Grinding Area       |              | O.D.                   |
| Grinding Range (mm) | O.D.(Max.)   | $\phi$ 1.0 ~ $\phi$ 10 |
|                     | Height(Max.) | 100                    |

### Shoe Type Centerless Grinder 3RG450A



Typical Grinding Applications

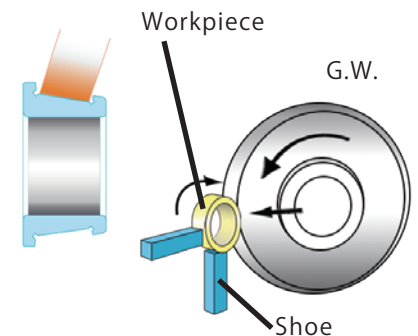

| Item                |              | Specification |
|---------------------|--------------|---------------|
| Grinding Area       |              | O.D.          |
| Grinding Range (mm) | O.D.(Max.)   | $\phi$ 150    |
|                     | Height(Max.) | 50            |

## Contact Us

Click on '[Product Inquires](#)' for more information.